



Designation: E3090/E3090M – 19

Standard Test Methods for Strength Properties of Metal Ceiling Suspension Systems¹

This standard is issued under the fixed designation E3090/E3090M; the number immediately following the designation indicates the year of original adoption or, in the case of revision, the year of last revision. A number in parentheses indicates the year of last reapproval. A superscript epsilon (ϵ) indicates an editorial change since the last revision or reapproval.

INTRODUCTION

In the past mechanical properties of metal ceiling suspension systems have been buried in other standards such as Specification C635 and Practice E580. This test method is an attempt to pull all testing requirements into one document.

1. Scope

1.1 These test methods cover metal ceiling suspension systems used primarily to support acoustical tile, acoustical lay-in panels, or suspended T-bar type ceiling systems.

1.2 These test methods cover the determination of strength properties of suspended ceiling grid system components as follows:

Tests	Subsections
Load Carrying Capacity	5.1
Connection Strength in Tension	5.2.2; 5.2.4
Connection Strength in Compression	5.2.3; 5.2.5
Wire Pullout Resistance	5.3

1.3 The values stated in either SI units or inch-pound units are to be regarded separately as standard. The values stated in each system are not necessarily exact equivalents; therefore, to ensure conformance with the standard, each system shall be used independently of the other, and values from the two systems shall not be combined.

1.4 *The following safety hazards caveat pertains only to the test methods described in this specification. This standard does not purport to address all of the safety concerns, if any, associated with its use. It is the responsibility of the user of this standard to establish appropriate safety, health, and environmental practices and determine the applicability of regulatory limitations prior to use.*

1.5 *This international standard was developed in accordance with internationally recognized principles on standardization established in the Decision on Principles for the Development of International Standards, Guides and Recommendations issued by the World Trade Organization Technical Barriers to Trade (TBT) Committee.*

2. Referenced Documents

2.1 *ASTM Standards:*²

- C634 Terminology Relating to Building and Environmental Acoustics
- C635 Specification for Manufacture, Performance, and Testing of Metal Suspension Systems for Acoustical Tile and Lay-in Panel Ceilings
- E580 Practice for Installation of Ceiling Suspension Systems for Acoustical Tile and Lay-in Panels in Areas Subject to Earthquake Ground Motions
- E631 Terminology of Building Constructions

3. Terminology

3.1 For terminology relating to Building and Environmental Acoustics, see Terminology C634.

3.2 For terminology relating to Building Constructions, see Terminology E631.

3.3 *Definitions of Terms Specific to This Standard:*

3.3.1 *carrying channel, n*—metal section that supports the entire structural grid network in some forms of mechanical ceiling suspension systems.

3.3.1.1 *Discussion*—The carrying channels are usually suspended by hanger wires from the existing structure and the main runners are then attached to the channels.

3.3.2 *ceiling suspension system, n*—the entire network or grid of structural components, as defined by the ceiling suspension system manufacturer, that provides support for acoustical ceiling tile, acoustical ceiling panels, lighting fixtures, flexible sprinkler hose fittings and air diffusers.

3.3.2.1 *Discussion*—The manufacturer of the ceiling suspension system will define/designate which elements of the system are the structural components.

¹ These test methods are under the jurisdiction of ASTM Committee E33 on Building and Environmental Acoustics and are the direct responsibility of Subcommittee E33.04 on Application of Acoustical Materials and Systems.

Current edition approved Oct. 1, 2019. Published October 2019. Originally approved in 2017. Last previous edition approved in 2018 as E3090/E3090M – 18. DOI: 10.1520/E3090_E3090M-19.

² For referenced ASTM standards, visit the ASTM website, www.astm.org, or contact ASTM Customer Service at service@astm.org. For *Annual Book of ASTM Standards* volume information, refer to the standard's Document Summary page on the ASTM website.

3.3.3 *cross runner, n*—the secondary or cross beams of a mechanical ceiling suspension system.

3.3.3.1 *Discussion*—The cross runners usually support only the acoustical tile. In some forms of suspension systems, however, the cross runners also provide support for lighting fixtures, air diffusers, flexible sprinkler hose fittings, and other cross runners.

3.3.4 *cross runner connection, n*—cross runners are interconnected to each other at a cross runner to main runner intersection.

3.3.5 *cross runner to main runner intersection, n*—cross runners intersect a main runner along the length of the main runner and are terminated at the a slot or *rout* along the main runner length.

3.3.5.1 *Discussion*—In a typical intersection two cross runners intersect a main runner from opposing sides and share the same slot or *rout hole*.

3.3.6 *main runner splice, n*—the primary main tees of the ceiling suspension system are connected along their lengths with a splice that is typically made from the body material or a secondary material attached to the main tee.

3.3.6.1 *Discussion*—The ‘splice’ connection ensures the modularity of the connection and typically has no intersecting cross runners at the location of the splice.

3.3.7 *main runner, n*—the primary or main beams of the type of ceiling suspension system in which the structural members are mechanically locked together.

3.3.7.1 *Discussion*—The main runners provide direct support for cross runners, and may support lighting fixtures and air diffusers. In addition, the acoustical tile may also be directly supported by the main runners. In some forms of mechanical ceiling suspension systems, the main runners are supported by hanger wires attached directly to the existing structure. In other forms, the main runners (also referred to as “H” runners, “Z” bars, etc.) are installed perpendicular to carrying channels and are supported by specially designed sheet metal or wire clips attached to the carrying channels.

3.3.8 *primary structural member, n*—the member that is under test in the load carrying capacity test (5.1).

3.3.8.1 *Discussion*—The primary structural member is typically a main runner.

3.3.9 *rout or cross runner hole, n*—a slot in the web of the main runner which is designed to accept interlocking cross runner ends.

3.3.10 *secondary structural member, n*—optional member that is added to the load carrying capacity test (5.1) to provide horizontal support to the primary structural member.

3.3.10.1 *Discussion*—The secondary structural member is typically a cross runner.

3.3.11 *suspended ceiling, n*—a ceiling in which the main runners and cross runners are suspended below the structural members of the building.

3.3.11.1 *Discussion*—Fig. 1 illustrates several common ceiling suspension systems.

4. Significance and Use

4.1 Load Carrying Capacity:

4.1.1 Most architectural specifications contain a uniform load requirement based on Specification C635. Additionally, it is useful to know the uniform loads of cross runners to evaluate their suitability for various ceiling loads.

4.1.2 The procedure detailed in this standard is intended to be used for the simple 4 ft span specified in Specification C635 but it can be used for simple spans other than 4 ft.

4.1.3 Various concentrated load combinations can be similarly tested or they can be calculated from the uniform load results by engineering analysis.

4.2 Connection Strength in Tension and Compression:

4.2.1 Structural failure of grid systems under axial loading is controlled by the failure of connections between the grid members. Specification of the allowable axial loads is useful for designers and specifiers for determining which grid systems will be appropriate for specific job conditions.

4.2.2 Connection strength is particularly important where the grid installation is expected to experience lateral loads due to earthquake or wind.

4.2.3 Connection strength in both compression and in tension are specified in Practice E580 as mean ultimate test load in tension and in compression.

5. Test Methods

5.1 Load Carrying Capacity:

5.1.1 *Apparatus – Support Frame*—Provide a rectangular support frame having the essential features of the unit described below:

5.1.1.1 The support frame (Fig. 2) shall have the capability for length adjustment to permit testing of structural members on clear spans for a maximum of 8 ft [2400 mm] to a minimum of 3 ft [900 mm]. It shall have the capability for overall width adjustment from a maximum of 4 ft [1200 mm] to a minimum of 2 ft [600 mm].

5.1.1.2 The support frame shall have sufficient stiffness so that no significant deflection occurs within the frame during load tests of suspension system structural members.

5.1.1.3 The support frame shall be either ceiling mounted or floor supported.

5.1.1.4 Both ends of the test specimen must be supported by a ¼ in. [6 mm] radius support.

5.1.2 *Test Specimen*—The structural members tested shall be identical to the sections used in the final system design. All cutouts, slots, etc., as exist in the system component shall be included in the sections evaluated.

5.1.2.1 Main runners/cross runners that are part of a fire resistance rated assembly that contain fire expansion relief cutouts shall be evaluated for load performance where field application of the expansion relief is designed to be more than 3 in. [75 mm] from the closest support point.

5.1.2.2 Allowable mill variations of sheet stock thickness can have a significant effect on section stiffness and load carrying ability. Consequently, load-deflection studies of structural members shall utilize sections fabricated in accordance with the system manufacturers’ published metal thicknesses and dimensions.

5.1.2.3 The length of the specimen may not exceed the length of the span being tested by more than 12 in. [300 mm].

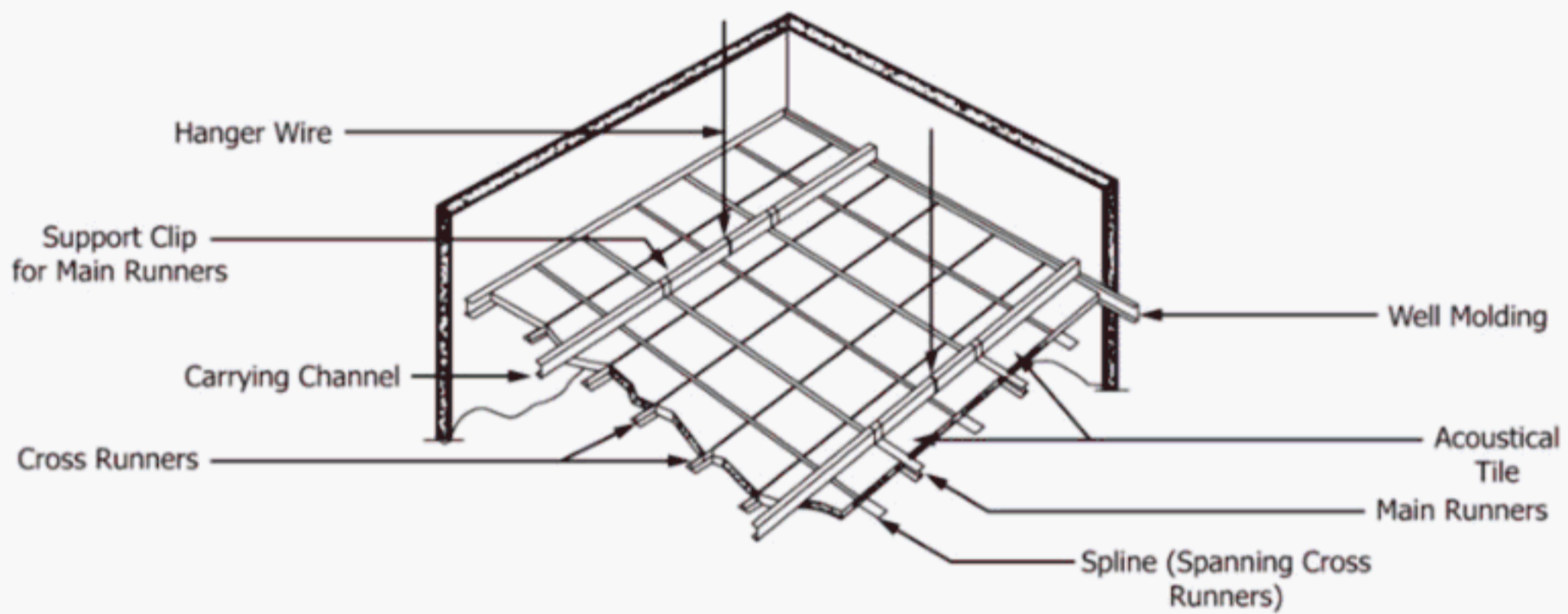
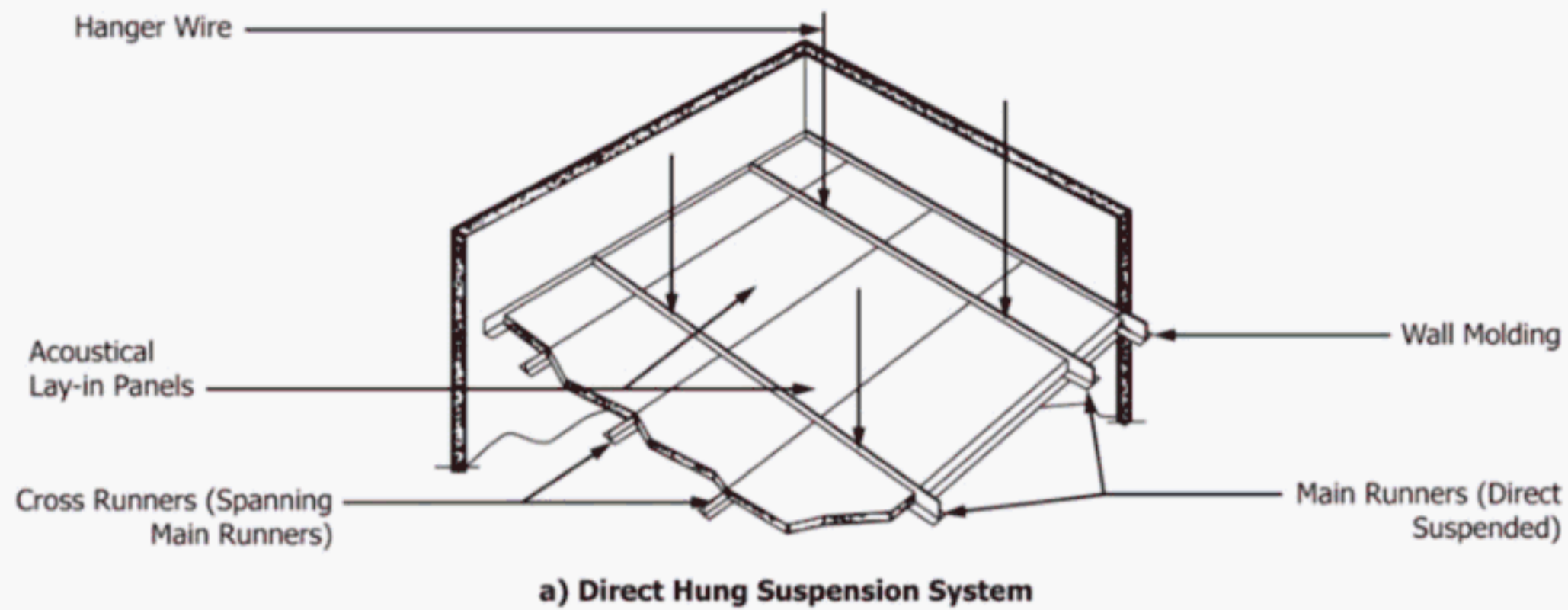
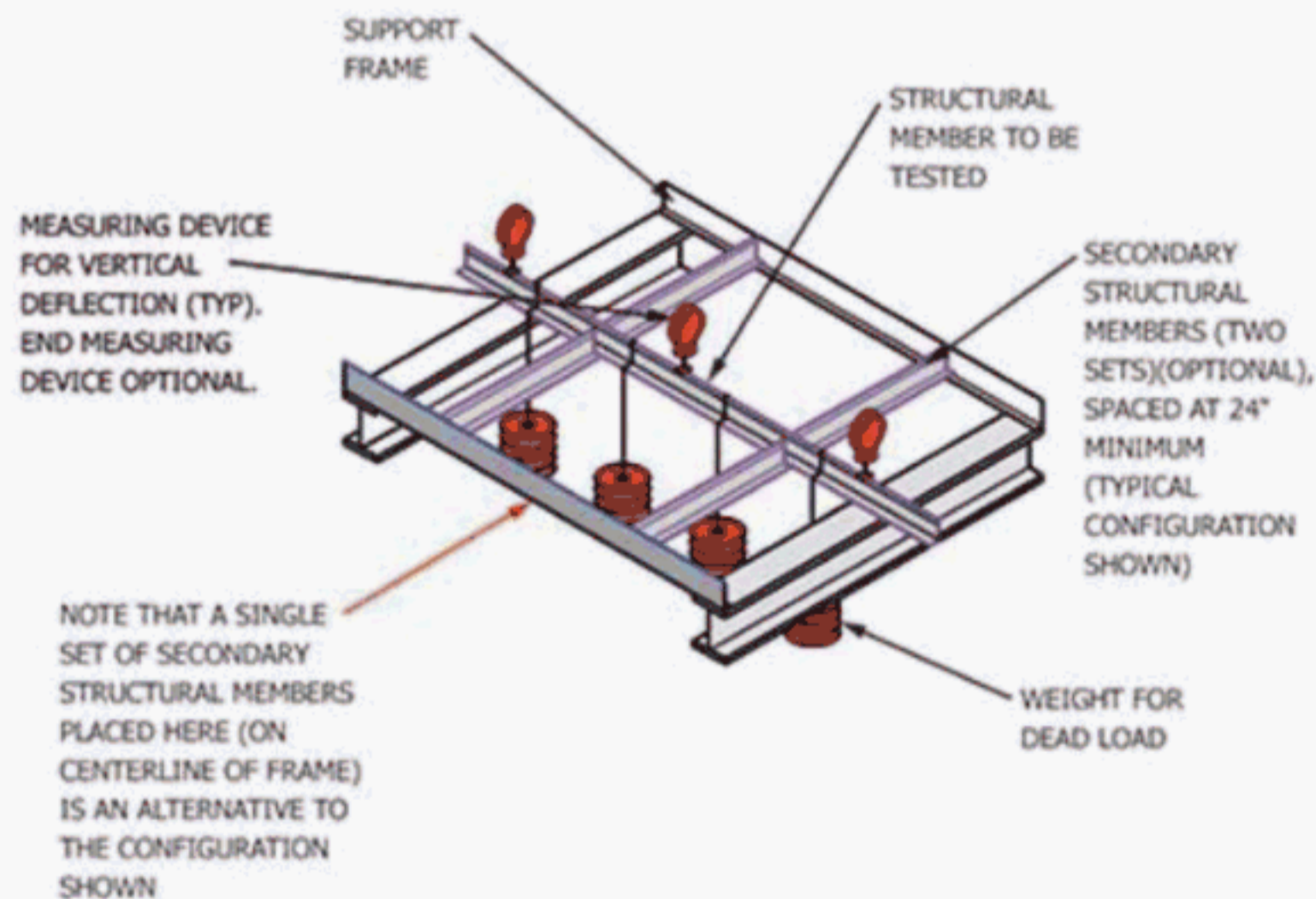

FIG. 1 Suspension System Types



5.1.2.4 In actual ceiling installations, the lateral (horizontal) buckling of structural members is prevented by the lateral support provided by intersecting structural members. When secondary structural members are used in a test system, they

provide the needed lateral (horizontal) support but make no direct contribution to the load-deflection performance in terms of vertical support of the primary structural member being tested.

5.1.2.5 Prevent lateral (horizontal) buckling of the section during testing by installing secondary members between the test specimen and the vertical sides of the support frame. Install secondary members normal to the direction of the primary structural member. Install secondary members no closer than 24 in. [600 mm] apart. Secondary member placement shall be symmetrical about both horizontal centerlines of the support frame. Lateral bracing should be representative of actual ceiling modules. Do not use additional materials, such as panels or tiles, to provide lateral support.

5.1.2.6 The secondary structural members may be either be interlocking type (such as with use of an actual cross runner) or non-interlocking type. Where interlocking secondary members are used, assemble them into the structural member being tested in customary fashion, and support the other end with the side of the support frame. Where non-interlocking secondary members are used, support one end of secondary members from the flange of the primary structural member (Fig. 2), and support the other end with the side of the support frame.

5.1.2.7 Clearances between the ends of the secondary structural member and the support frame shall be typical of that which exists in the actual ceiling system. Secondary members must not interlock with the perimeter support frame.

5.1.2.8 During testing, any lateral (horizontal) buckling tendency will be defeated as the secondary structural member, supported laterally (horizontally) by the vertical side of the support frame, bears on the web of the primary structural member. This type of setup provides a means for giving at least a partial recognition of the enhancement of load-carrying capability that other structural members contribute to grid systems with respect to lateral (horizontal) support. The secondary structural member shall not provide vertical support to the primary structural member.

5.1.3 Section Loading:

5.1.3.1 With the structural member to be evaluated installed in the support frame, position the support frame to mount the vertical displacement deflection measuring devices directly over the test section at the mid-span. As an option, additional deflection measuring devices may be mounted at each end of the test section at the rest supports. The optional end measuring

device may be used when a test section exhibits a tendency to compact at the rest supports. Position the measuring device to read zero with reference to a horizontal plane that runs through the supports of the structural member in the test support frame. Incorporate the weight of hanger wires, pans, etc., as part of the first incremental test load.

5.1.3.2 Apply the test weights (Fig. 3 and Fig. 4), simulating the weight of ceiling tile or panel, to the structural member starting 6 in. [150 mm] from the end supports, and at 1-ft [300 mm] intervals thereafter, always proceeding from the ends toward the center of the span in applying the load. Each weight attachment to the structural member must be such that the contact surface is no greater than 1 in. [25 mm] in the direction of the length of the structural member, in order to ensure that the weight attachment does not increase the rigidity of the structural member. After the first uniformly distributed load increment has been applied, measure and record the mid-span deflection of the structural member. Also record the end measuring device deflections when the end measuring device is present. Measure and record the loading of the structural member. Continue loading of the structural member in the same manner, applying successive increments of uniformly distributed load and observing the deflections after each increment. Continue loading until it is apparent that the test section has collapsed and will not support any further load.

5.1.3.3 Record the incrementally applied uniformly distributed loads and the resultant mid-span deflection measurements for each loading. When end measuring devices are used, subtract the average value of the two end measuring devices from the corresponding mid-span deflection, and report the resultant net mid-span deflection for each increment. Subtracting the average end measuring device readings will compensate for vertical translation of the test section due to compaction at the rest supports.

5.1.3.4 Determine the load-deflection performance of secondary structural members by setting up and testing the cross tee members in a manner appropriate to their use in actual grid systems.

5.1.4 Calculations:

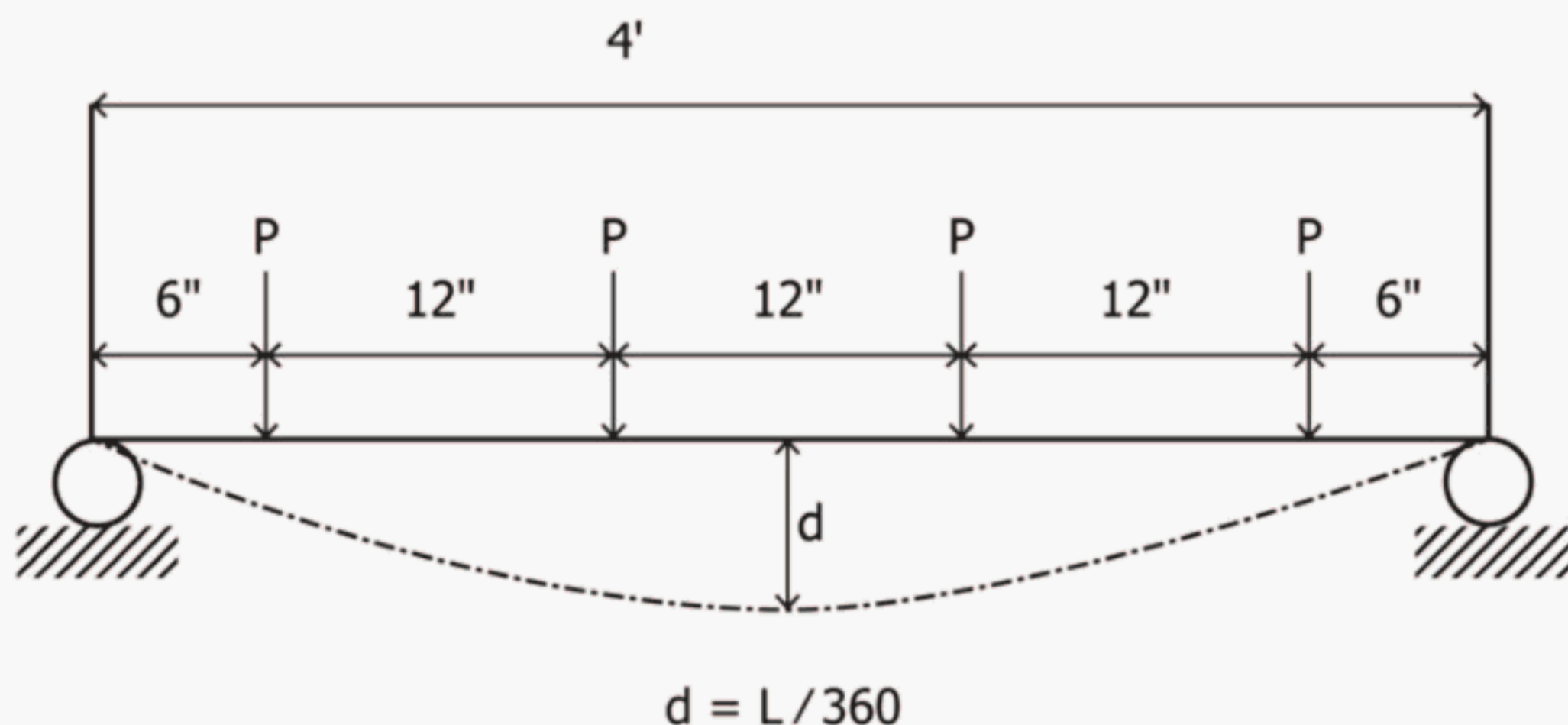

FIG. 3 Load-Carrying Test Configuration for Inch-Pound Units

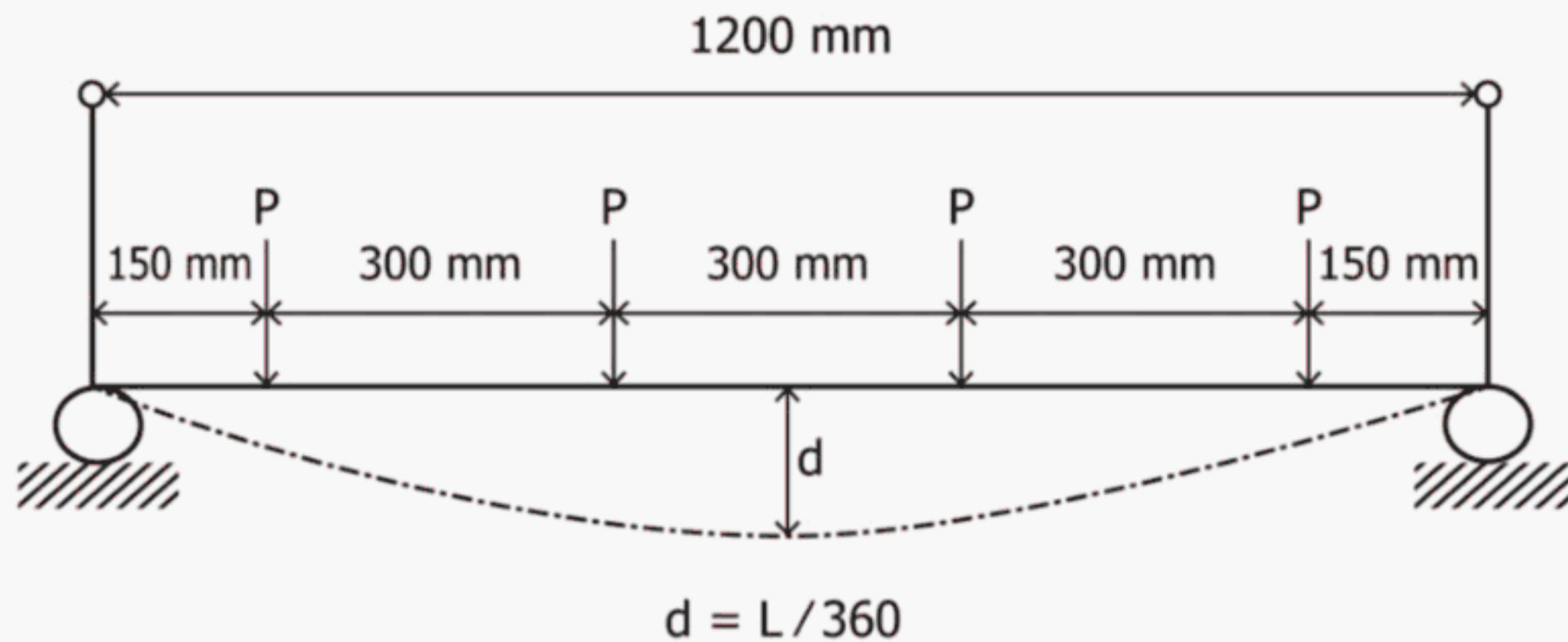

FIG. 4 Load-Carrying Test Configuration for SI Units

5.1.4.1 The performance of structural members of suspension systems is represented by individual load-deflection tests performed at each different span length used in service.

5.1.4.2 For each structural member under evaluation and each span length, test and perform calculations on three replicate test specimens and average the resulting values, prior to reporting the results.

5.1.4.3 Use the average load data to establish the maximum uniformly distributed load that the structural member can successfully sustain prior to reaching the deflection limit of $L/360$ of the span length in inches [millimeters] according to the following formula:

$$\text{load at } \frac{L}{360} = \text{last load value before reaching } \frac{L}{360} + \left(\text{load past } \frac{L}{360} - \text{load before } \frac{L}{360} \right) \frac{\left(\frac{L}{360} - \text{deflection before } \frac{L}{360} \right)}{\left(\text{deflection after } \frac{L}{360} - \text{deflection before } \frac{L}{360} \right)} \quad (1)$$

where:

L = span length

5.1.5 Report:

5.1.5.1 A test log shall be prepared to record all pertinent data regarding the structural member being evaluated and the principal accessory items used including secondary structural members. The following shall be provided:

- (1) Manufacturer's name,
- (2) Suspension system identification,
- (3) Test system identification,
- (4) Description of section, measured overall height, width, and thickness of basic stock, type of material, section weight, etc.,
- (5) Test span length,
- (6) Spacing of lateral supports,
- (7) Identification of accessory items including secondary structural members and how used,
- (8) Maximum uniformly distributed load at failure,

(9) Maximum uniformly distributed load at $L/360$ deflection, and

(10) Calibration data for deflection measuring device.

5.1.6 Precision and Bias—No statement is made on the precision or on the bias of these methods since no data are available at this time that are based on the use of the test methods described.

5.2 Connection Strength:

5.2.1 Apparatus:

5.2.1.1 Testing Machine—A standard testing machine capable of applying and measuring the required load within an accuracy of 1 % shall be used.

5.2.1.2 Attach the test specimen to the testing machine using a fixture designed to prevent local failure or slippage at the attachment point before failure of the connection.

5.2.1.3 Fixtures described in 5.2 represent where force may be applied to constrain a test specimen, in order to isolate the failure to the actual connection that is under test. Additional constraints, such as from the use of ceiling tiles or secondary intersection clips, shall not be added to the test set-up.

5.2.2 Tension Testing Main Runner Splice:

5.2.2.1 The length of each of the two sections of main runner shall be a minimum of 6 in. [150 mm].

5.2.2.2 Attach the test specimen to the test fixture, as shown in Fig. 5. Position the testing machine to remove any slack and impose a preload of 5 lbf [22 N] before beginning the test.

5.2.2.3 Ensure that the fixtures are in line so that the force is applied axially for a straight tension test with no significant moments induced.

5.2.2.4 Increase the applied load at a constant rate until the maximum load is reached. The rate may range from 1 to 10 lb/s [4.4 to 44 N/s] or 0.5 in./min [12.7 mm/min].

5.2.2.5 Seismic requirements require a tension test with an applied 5° angle. This shall be achieved by using a fixture to push the connection out of alignment. The contact surface of the fixture shall not be greater than 1/8 in. [3 mm], $\angle a + \angle b \geq 5^\circ$. See Fig. 6 and Fig. 7. Instead of 5° misalignment, the load can be applied with a 1-in. [25 mm] eccentricity on a sample not more than 24 in. [600 mm] long on each side of the splice or intersection.

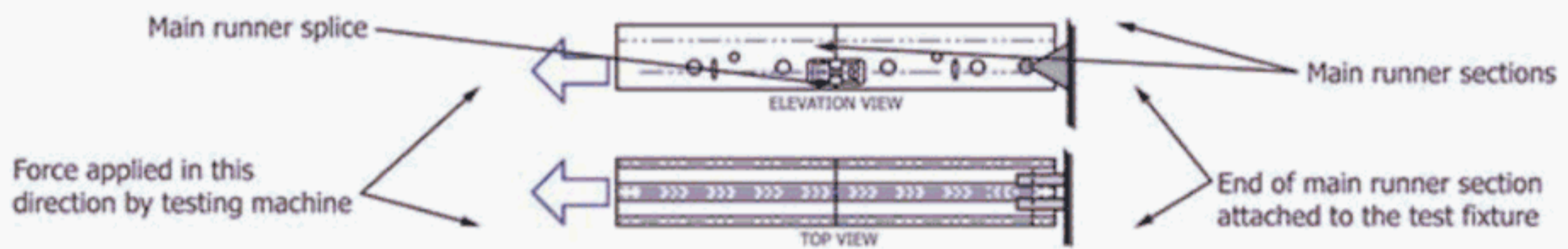

FIG. 5 Main Runner Splice in Straight Tension Test

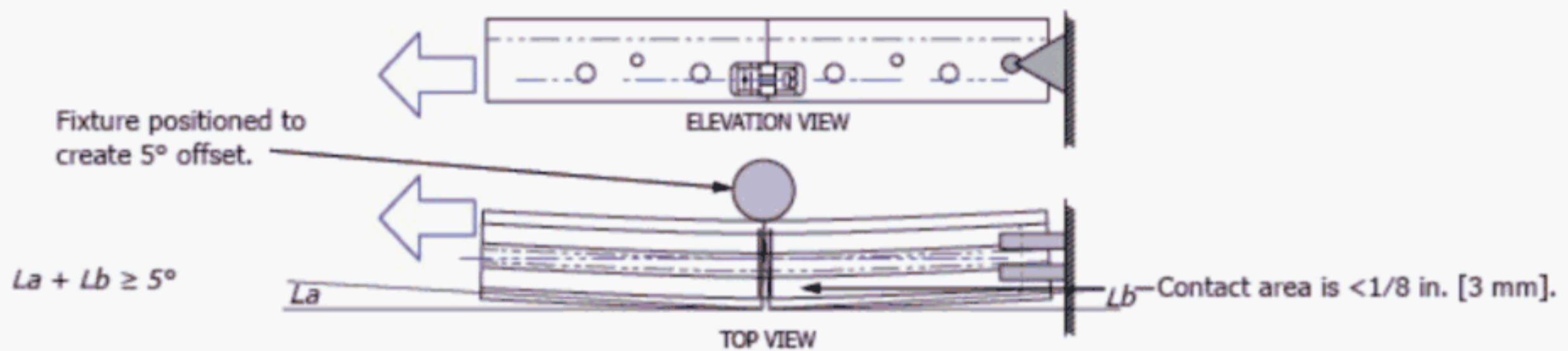

FIG. 6 Main runner splice with fixture used to achieve 5° angle in horizontal direction

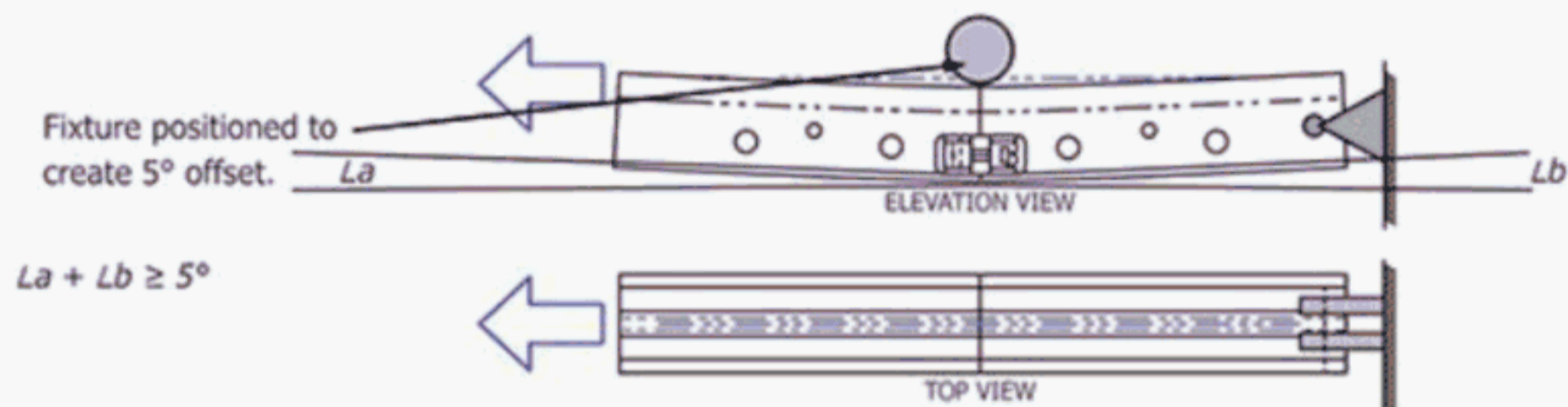

FIG. 7 Main runner splice with fixture used to achieve 5° angle in vertical direction

5.2.3 Compression Testing Main Runner Splice:

5.2.3.1 The length of each of the two sections of main runner shall be a minimum of 6 in. [150 mm].

5.2.3.2 Attach the test specimen to the test fixture, as shown in Fig. 8. Position the testing machine to remove any slack and impose a preload of 10 lb [4.5 kg] before beginning the test.

5.2.3.3 Ensure that the fixtures are in line so that the force is applied axially for a straight compression test with no significant moments induced. See Fig. 8.

5.2.3.4 Increase the applied load at a constant rate until the maximum load is reached. The rate may range from 1 to 10 lb/s [4.4 to 44 N/s] or 0.5 in./min [12.7 mm/min].

5.2.4 Tension Testing Cross Runner Connection:

5.2.4.1 The length of each section of runner (two cross runner sections and one main runner section) shall be a minimum of 6 in. [150 mm].

5.2.4.2 Attach the test specimen to the test fixture, as shown in Fig. 9. Position the testing machine to remove any slack and impose a preload of 5 lb [2.25 kg] before beginning the test.

5.2.4.3 Ensure that the fixtures are in line so that the force is applied axially for a straight tension test with no significant moments induced.

5.2.4.4 Increase the applied load at a constant rate until the maximum load is reached. The rate may range from one to 10 lb/s [4.4 to 44 N/s] or 0.5 in./min [12.7 mm/min].

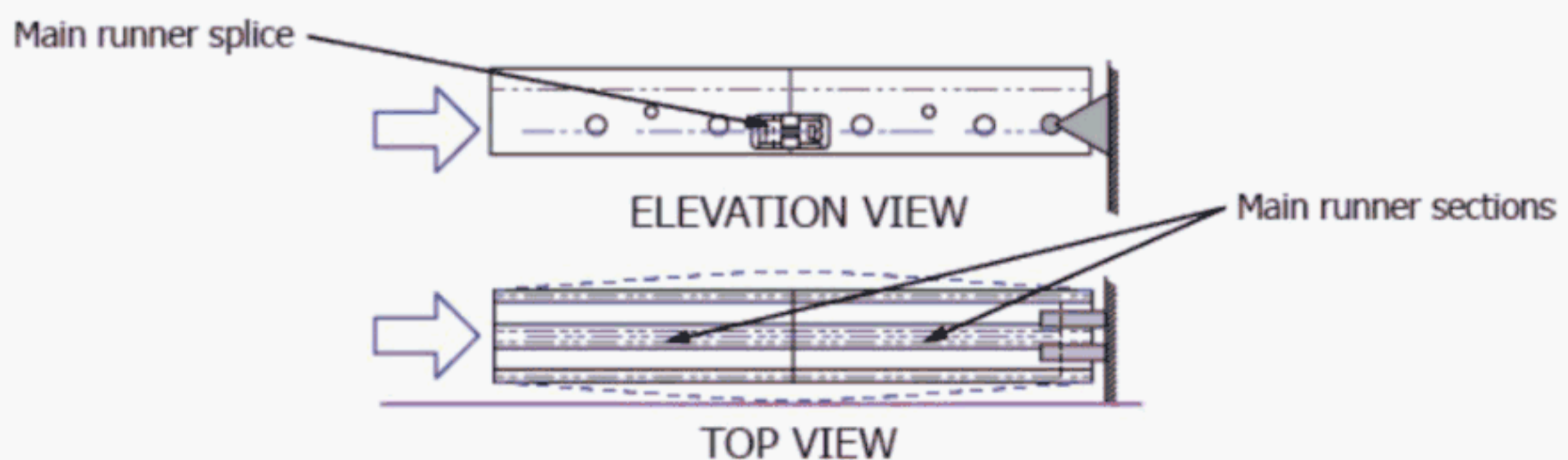

FIG. 8 Main Runner Splice in Compression Test

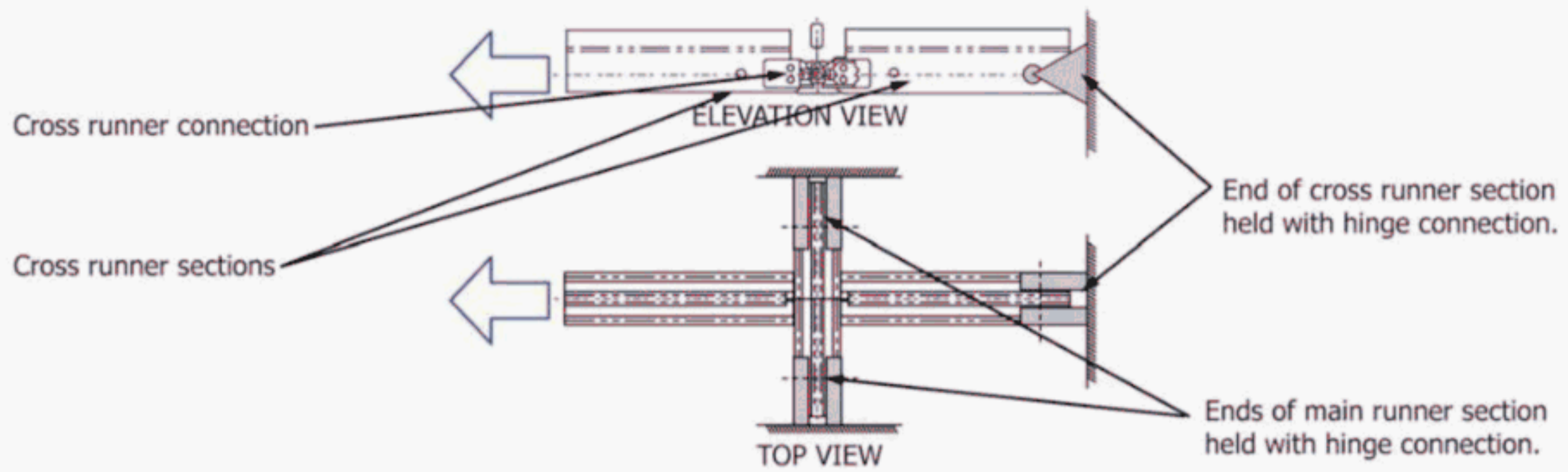

FIG. 9 Cross Runner Connection in Straight Tension Test

5.2.4.5 Seismic requirements require a tension test with an applied 5° angle. This shall be achieved by positioning and fixing the main runner so that the connection is out of alignment, $\angle a + \angle b \geq 5^\circ$. See Fig. 10 and Fig. 11. Instead of 5° misalignment, the load can be applied with a 1-in. [25 mm] eccentricity on a sample not more than 24 in. [600 mm] long on each side of the splice or intersection.

5.2.5 Compression Testing Cross Runner Connection:

5.2.5.1 The length of each section of runner (two cross runner sections) shall be a minimum of 6 in. [150 mm].

5.2.5.2 Attach the test specimen to the test fixture, as shown in Fig. 12.

5.2.5.3 Ensure that the fixtures are in line so that the force is applied axially for a straight compression test with no significant moments induced. Since compression tests are sensitive to misalignment due to buckling, the main tee shall be fixed to limit the buckling.

5.2.5.4 Increase the applied load at a constant rate until the maximum load is reached. The rate may range from 1 to 10 lb/s [4.4 to 44 N/s] or 0.5 in./min [12.7 mm/min].

5.2.6 Calculations—Evaluation of test results shall be made on the mean values resulting from tests on a minimum of three identical specimens. If the deviation of any individual test result exceeds $\pm 10\%$ from the mean value, three additional samples shall be tested. After the required testing on the six specimens is complete, drop the high and low test values and use the remaining four test results to obtain the mean test value

average. If one of the remaining test results still exceeds the $\pm 10\%$ mean value, the lowest individual test value recorded from the six tests will be used as the reported test result.

5.2.7 Report—Report the mean test value in both compression and tension.

5.2.8 Precision and Bias—No statement is made on the precision or on the bias of these methods since no data are available at this time that are based on the use of the test methods described.

5.3 Wire Pullout Resistance:

5.3.1 Apparatus:

5.3.1.1 A standard testing machine capable of applying and measuring the required load within an accuracy of 1% shall be used.

5.3.1.2 Attach the test specimen to the testing machine using a fixture designed to prevent failure or slippage at the machine/specimen connection point before failure at the wire/specimen connection point.

5.3.1.3 Use No. 12 gauge [2.68 mm] soft annealed, mild steel wire to test the specimen. Each wire shall be attached to the test specimen such that the wire loops are tightly wrapped and sharply bent to prevent any vertical movement or rotation of the member within the loops. The wire must be wrapped around itself a minimum of three full turns (360° each) within a 3-in. [75-mm] length.

5.3.2 Specimen Preparation:

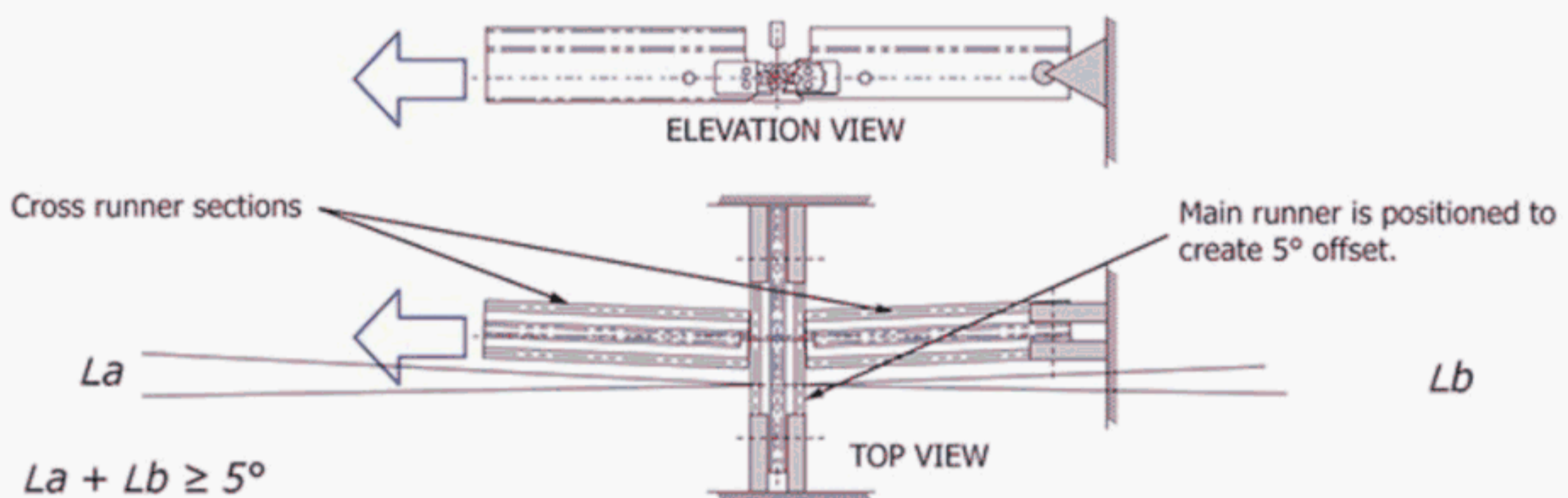

FIG. 10 Cross runner connection with main runner positioned to achieve 5° angle in horizontal direction

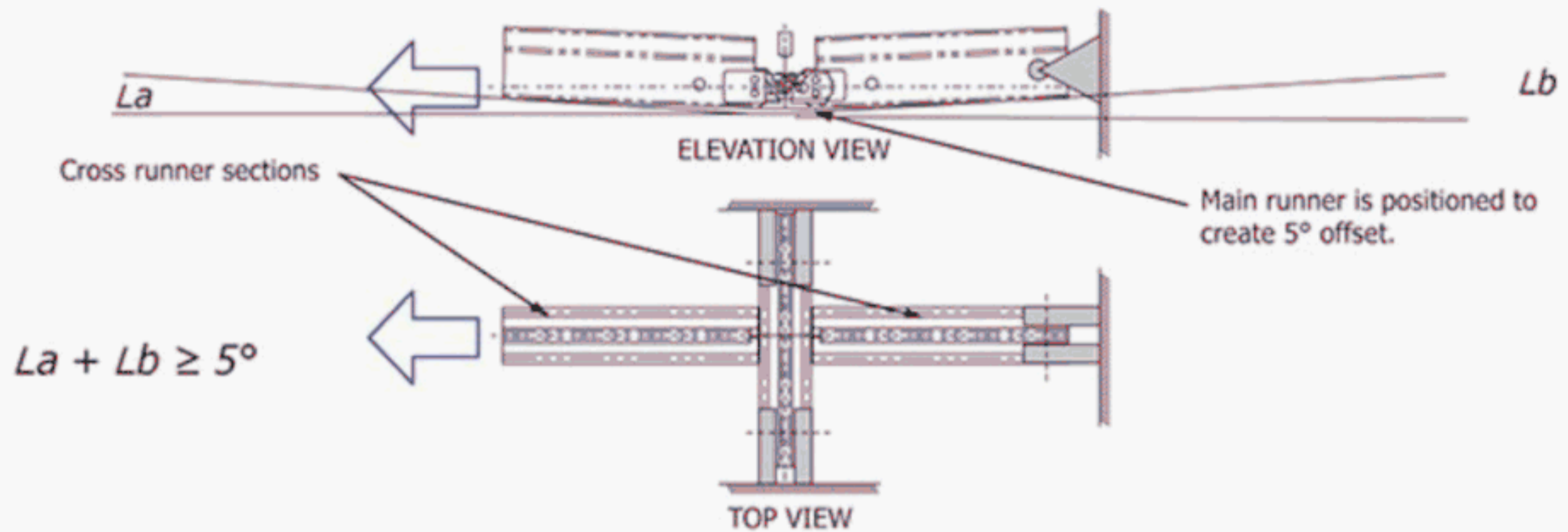

FIG. 11 Cross runner connection with main runner positioned to achieve 5° angle in vertical direction

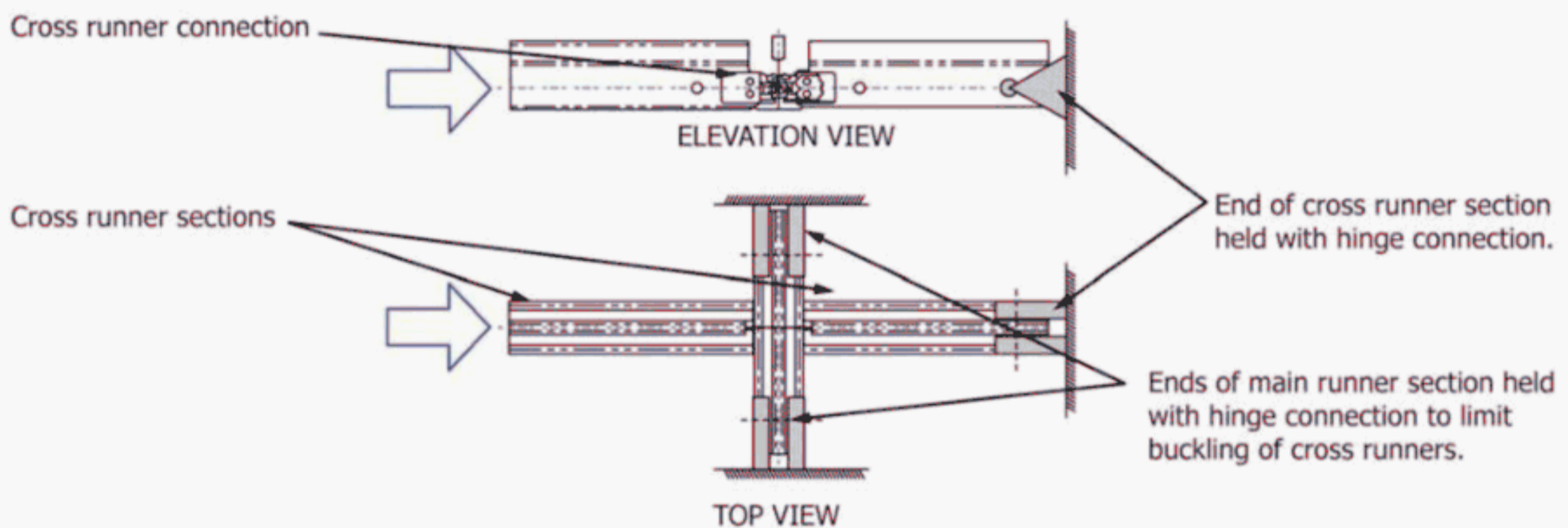

FIG. 12 Cross runner connection with main runner fixed to limit buckling

5.3.2.1 Cut a runner to create a section that is 6 in. [150 mm] in length or greater, and so that the wire connection point to be tested is no less than 3 in. [75 mm] from either end.

5.3.2.2 Minor modifications may be made to the test specimen, as needed, in order to fixture it to the testing machine. The wire connection region to be tested must not be modified, and any modifications made to the test specimen must not impact the pullout resistance of the wire connection region.

5.3.3 Test Procedure:

5.3.3.1 Fixture the test specimen so as to create a pullout force in one of the three directions defined in Fig. 13, Fig. 14,

and Fig. 15.

5.3.3.2 Attach the wire to the test specimen and fixture the other end of the wire to the testing machine. Remove slack from the wire.

5.3.3.3 Increase the applied load at a constant rate until the maximum load is reached. The rate may range from 1 to 10 lb/s [0.45 to 4.5 kg/s] or 0.5 in./min [12.7 mm/min].

5.3.4 Replicate Evaluation—A minimum of three specimens shall be tested for each configuration. The deviation of any individual test result from the mean value shall not exceed 10 %. If the deviation of any individual result exceeds $\pm 10\%$ from the mean value, three additional samples shall be tested.

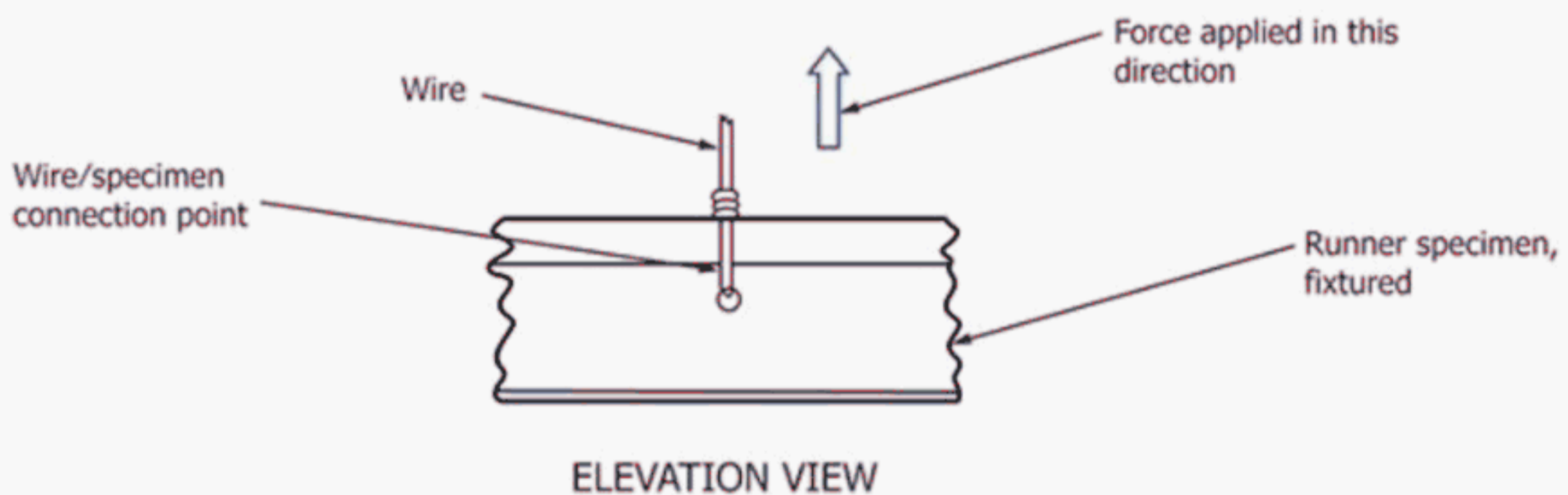
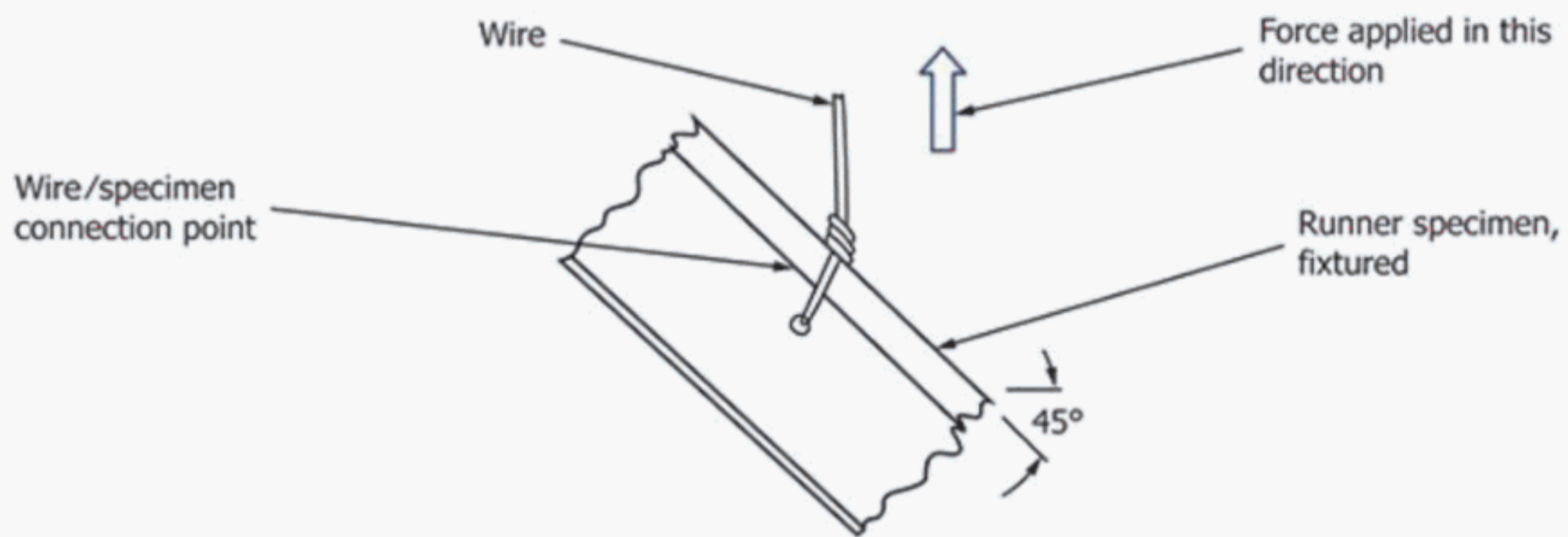
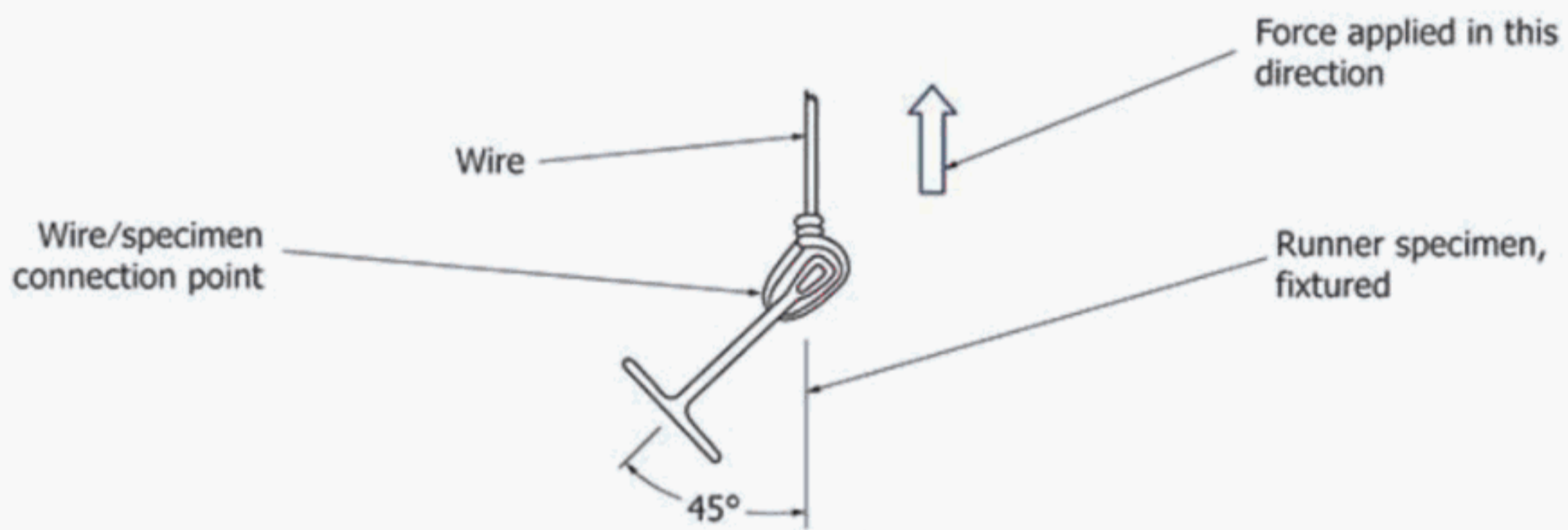

FIG. 13 Straight Pullout



ELEVATION VIEW

FIG. 14 45° Planar Offset Pullout



END VIEW

FIG. 15 45° Non-Planar Offset Pullout

After the required testing on the six specimens is complete, the high and low test values are dropped and the remaining four test results are used to obtain the mean test value average. If one of the remaining test results still exceeds the $\pm 10\%$ mean value, the lowest individual test value recorded from the six tests will be used as the reported test result.

5.3.5 Report—Report the wire pullout resistance value that is the output of 5.3.4 and indicate the failure mode of either wire pull through or wire tensile failure.

5.3.6 Precision and Bias—No statement is made on the precision or on the bias of these methods since no data are available at this time that are based on the use of the test methods described.

6. Keywords

6.1 ceiling suspension mechanical properties; connection strength in compression; connection strength in tension; load carrying capacity

ASTM International takes no position respecting the validity of any patent rights asserted in connection with any item mentioned in this standard. Users of this standard are expressly advised that determination of the validity of any such patent rights, and the risk of infringement of such rights, are entirely their own responsibility.

This standard is subject to revision at any time by the responsible technical committee and must be reviewed every five years and if not revised, either reapproved or withdrawn. Your comments are invited either for revision of this standard or for additional standards and should be addressed to ASTM International Headquarters. Your comments will receive careful consideration at a meeting of the responsible technical committee, which you may attend. If you feel that your comments have not received a fair hearing you should make your views known to the ASTM Committee on Standards, at the address shown below.

This standard is copyrighted by ASTM International, 100 Barr Harbor Drive, PO Box C700, West Conshohocken, PA 19428-2959, United States. Individual reprints (single or multiple copies) of this standard may be obtained by contacting ASTM at the above address or at 610-832-9585 (phone), 610-832-9555 (fax), or service@astm.org (e-mail); or through the ASTM website (www.astm.org). Permission rights to photocopy the standard may also be secured from the Copyright Clearance Center, 222 Rosewood Drive, Danvers, MA 01923, Tel: (978) 646-2600; http://www.copyright.com/